



STANDARD FEATURES

- Manufactured in USA
- **Custom tray sizes and lengths**
- Polycord belt slide on stainless steel slider bed for a smooth operation
- All 304 stainless steel construction with a #4 finish
- 12mm dia polypropylene belt with woven nylon core reinforcement
- Adjustable speed control in NEMA 4 control cabinet with programmable AC inverter
- Optional Casters (with brake) and cord/plug available for mobile unit
- Unit supported on 1-5/8" diameter 16 gauge wall polished stainless steel tubular legs with fully welded 1-5/8" cross bracing
- Optional electrical raceway with receptacles for plug-in side equipment
- Limit switch at the end of the belt
- Sanitary design with easy cleaning of belt and conveyor bed
- Smooth operation with low amp draw

Tray Make-UP

PCM2 - Polycord Belt Conveyor

PCM2 CONVEYOR

Bi-line PCM2 conveyor is designed for tray make-up application. Sanitary design with a 1/2" mm dia polypropylene belt (with woven nylon core reinforcement) smoothly running on stainless steel slider bed. Custom options available to suit operational requirement.

SPECIFIER STATEMENT

Specified Unit will be Bi-line Model PCM2 conveyor. 1/2" mm dia polypropylene belt with woven nylon core reinforcement supported on stainless steel slider bed for a smooth running operation. Accumulation switch provided at the end of belt line. Additional options to be included per detailed drawing to meet operational requirement.

OPTIONS & ACCESSORIES

- Custom size and shape per plan
- Single over-shelf
- Double over-shelf
- Hip/palm advance button
- Foot advance switch
- Locking casters
- Electrical raceway with multiple outlets
- Cantilevered sliding work shelves
- Limit switch – mechanical
- Limit switch – photo eye
- Adjustable feet

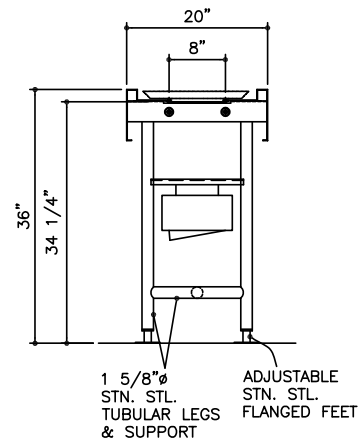

Section View

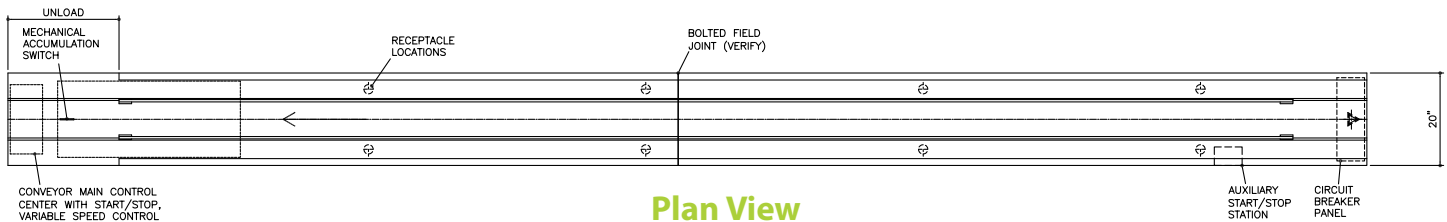

Plan View

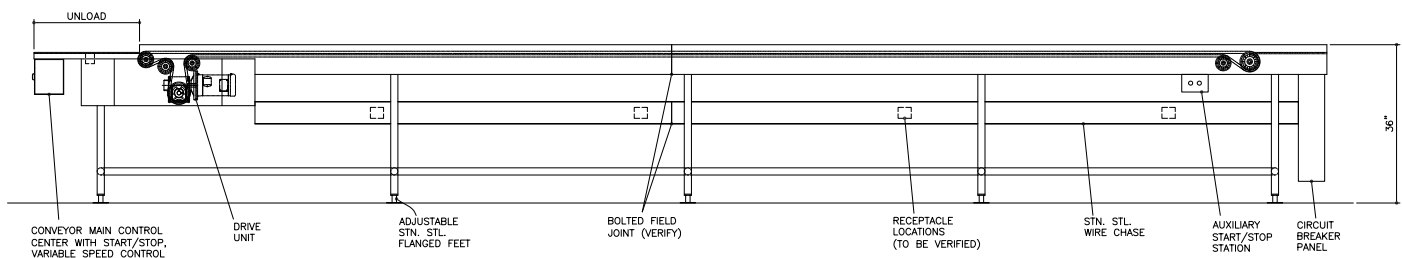

Front View

Due to an ongoing value analysis program at Bi-Line, specifications contained in this catalog are subject to change without notice.

Contact factory for custom design layout

www.bilinesystems.com
info@bilinesystems.com
Rev. 7/24 Printed in U.S.A.

3765 Champion Blvd, Winston-Salem, NC 27105
Tel: 336-661-1556 Fax: 336-661-1979

2674 N. Service Rd, Jordan Station, Ontario, Canada L0R 1S0
Tel: 800-263-5798 Fax: 905-562-4618